

MERAWEX sp. z o.o.
44-122 Gliwice
ul. Toruńska 8
Phone: +48 32 23 99 400
e-mail: merawex@merawex.com.pl
www: <http://www.merawex.com.pl>

USER MANUAL

Power supplies for fire gates and fire automation systems ZUP-230V-BM-400S, ZUP-230V-BM-700S, ZUP-230V-BM-1000S, ZUP-230V-BM-700M, ZUP-230V-BM-1000M, ZUP-230V-BM-1500L

According to EN 54-4:1997 + AC:1999 + A1:2002 + A2:2006
and EN 12101-10:2005 + AC:2007
CNBOP-PIB Certificate of Constancy of Performance No. 1438-CPR-0761
Declaration of Performance DWU-MX-19
CNBOP-PIB Approval Certificate No. 4300/2021

01.10.2025

Table of contents

1. Technical description	2
1.1. Intended use	2
1.2. Available power supply types	4
1.3. Technical data	4
2. Construction and principle of operation of the power supply	7
2.1. Operation in CSP mode for air gates	9
2.2. Operation in UPS mode	10
2.3. EPO circuit breaker	11
3. Detailed description of the power supply operation	12
3.1. CSP mode	12
3.2. UPS mode	15
4. Description of ZUP-BM board	16
5. Installation	19
5.1. General notes	19
5.2. Connection of mains supply	19
5.3. Connection of 230Vac circuits	20
5.4. Connecting the battery	20
5.5. Emergency operation with one power source.	20
5.6. Connection of control inputs	21
5.7. First start-up	22
5.7.1. Starting the power supply in CSP mode.	22
5.8. Power supply configuration	25
6. Maintenance and service	27

7. Additional information	27
7.1. Manufacturer's remarks	27
7.2. Compulsory technical inspection	27
7.3. CE marking	28
7.4. Handling of packaging, worn-out products and batteries	29

Warnings

- **Please read this User Manual carefully before operating the device.**
- **Do not touch the internal parts of the operating device - it may cause electric shock or burns.**
- **Prevent any objects or liquids from entering the device - this may cause electric shocks and damage to the device.**
- **Do not cover the ventilation holes - it may damage the device.**
- **Provide a clear space of at least 10cm on the sides of the device to enable proper ventilation.**
- **It is forbidden to carry or transport the device with batteries installed and connected.**
- **The device must be powered from the mains with a protective earthing terminal.**
- **This device may interfere with sensitive radio and television equipment in the vicinity.**
- **The device may only be operated by authorised and trained personnel.**
- **The device may only be serviced by the manufacturer's service staff or by specialised units authorised by the manufacturer.**

1. Technical description

1.1. Intended use

Power supply with battery backup type ZUP-230V-BM supplies uninterruptible 230V power from the mains or, in the event of a power failure, 230Vac from a DC/AC inverter powered by an internal 24V battery.

The inverter used offers a high-quality stabilised sinusoidal output voltage of 230V 50Hz. The inverter can be loaded with any type of receiver (inductive, capacitive, resistive).

The ZUP-230V-BM power supply is designed for operation in two modes: CSP and UPS. The CSP mode, working with the Control and Indicating Equipment, is intended to control the opening of gates which, in the event of a fire, in addition to their communication function, are used to help remove smoke from the building by acting as air gates. UPS mode can be used wherever an uninterruptible 230Vac power supply is required. The power supply additionally features an input for connecting an EPO (Emergency Power OFF) circuit breaker, allowing it to be switched off completely.

The basic versions of the power supplies with 400W, 700W and 1000W are mounted in the small cabinet (**S** type). The power supplies in the middle (**M** type) and large (**L** type) cabinets can additionally be equipped with an uninterruptible 24Vdc power supply output.

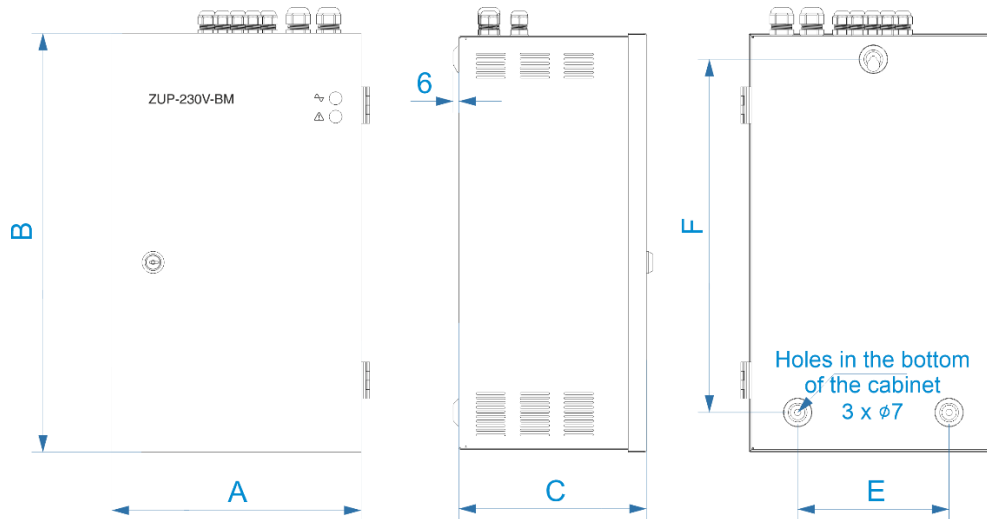

Fig.1.a. Dimension and spacing of fixing holes of ZUP-230V-BM power supplies in **S** type cabinet.

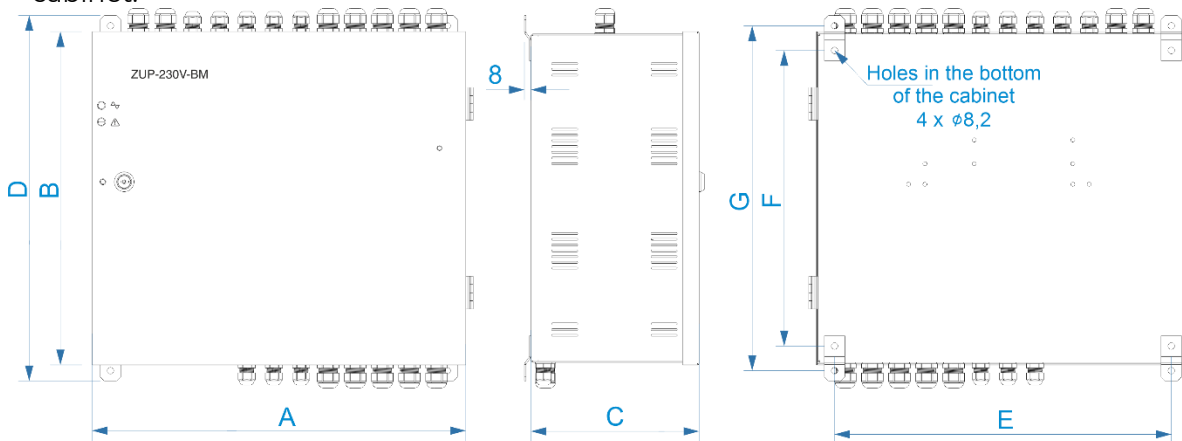

Fig.1.b. Dimension and spacing of fixing holes of ZUP-230V-BM power supplies in **M** and **L** type cabinets.

Power supply housings have prepared holes for glands and additional blinded holes intended for mechanical removal. Permissible number of glands possible in a given type of enclosure:

- for **S** type cabinets:
 - in the upper part for 5 M16x1.5 glands and 2 M20x1.5 glands
- for **M** and **L** type cabinets:
 - in the upper part for 5 M16x1.5 glands and 7 M20x1.5 glands
 - in the bottom part for 3 M16x1.5 glands and 5 M20x1.5 glands

Overall dimensions of housings and weight of power supplies

Housing	Dimensions in mm							Applied to power supplies	Maximum weight with battery
	A	B	C	D	E	F	G		
S	272	457	205		165	385		ZUP-230V-BM -400S -700S -1000 S	21kg 22Ah
M	455	406	205	445	410	360	420	ZUP-230V-BM -700M -1000M	31kg 33Ah 38kg 45Ah
L	555	456	205	495	510	410	470	ZUP-230V-BM -1500L	41kg 45Ah 54kg 75Ah

In the L cabinet of the ZUP-230V-BM-1500 power supply it is also possible to mount batteries with larger capacities; from 50Ah to 75Ah. However, when using batteries with these

capacities, the power supply will not meet the requirements of EN 54-4 regarding the required battery charging time.

The following signs may be used interchangeably on the cabinet doors:

MAINS or **FAULT** or

Completion of the power supply

Equipment	Quantity	Notes
ZUP-230V-BM power supply	1	Fixed equipment depending on power supply type
75W or 150W rectifier	1	150W rectifier only in ZUP-230V-BM-1500L
Temperature probe	1	Power supply equipment
Battery wire (connector)	1	Equipped with 2 ends depending on battery type
Battery connection wires	2	Equipped with ends depending on battery type
M16×1.5 glands	2	Quantities can be changed in the order
M20×1.5 glands	2	Quantities can be changed in the order

Notes :

- the above general overview does not include optional modules (see 1.3.);
- 2x12V batteries must be ordered separately.

1.2. Available power supply types

An overview of the available power supply types is given below:

Power supply type	Inverter power	Housing type	Available battery capacity *4)						Optional equipment			
			12 Ah	18 Ah	22 Ah	26 Ah	33 Ah	45 Ah	50 ÷ 75 Ah	24Vdc output *1)	Relay module *2)	
ZUP-230V-BM-400S	400	S	+	+	+						+	
ZUP-230V-BM-700S	700		+	+	+							+
ZUP-230V-BM-1000S	1000			+	+							+
ZUP-230V-BM-700M	700	M				+	+			+	+	
ZUP-230V-BM-1000M	1000					+	+	+		+	+	
ZUP-230V-BM-1500L	1500	L				+	+	+	*3)	+	+	

*1) Module used: ZUP-230V-BM-24V

*2) Programmable relay module used: ZUP-TR

*3) Batteries above 45Ah can be placed in **L** type housing, but such a power supply will not comply with EN 54-4.

*4) Other capacities may be used, ranging between those indicated in the table. In this case, the power supply manufacturer should be asked to indicate the limitations.

1.3. Technical data

The table below is provided as a basis for meeting the requirements of the standards indicated:

- EN 54-4, which imposes a time limit of 24 hours for charging the battery to 80% of its capacity with the possibility of drawing I_{max_a} current for the needs of the supplied devices (I_{max_b} is the maximum, momentary current whose drawing does not allow such charging) and the maximum additional resistance $R_{i\ max}$ in the battery circuit;
- EN 12101-10, which defines the conditions for battery operation (when fully charged): waiting for the load (so-called supervision) during which the indicated current I_{max_a} may be drawn for 72h and the maximum short-duration current I_{max_b} for 180s.

In the columns of the table that are assigned to the currents described by the standards, for the 230Vac output, the power that can be drawn from this output, under the same conditions as the current, is entered.

The tables present only such combinations that result from possible configurations of the ZUP-230V-BM power supply (see 1.2.)

Permitted output loads according to EN 54-4

Power supply type	I_{max_b}		I_{max_a}	I_{max_a} for 24Vdc output in A for batteries with capacities					
	230Vac	24Vdc	230Vac						
	W	A	W	12Ah	18Ah	22Ah	26Ah	33Ah	45Ah
ZUP-230V-BM-	700	2.27	700				1.21	0.92	
ZUP-230V-BM-	1000	2.16	1000				1.11	0.82	0.33
ZUP-230V-BM-	1500	3.0	1500				3.0	3.0	3.0

Permitted output loads according to EN 12101-10

Power supply type	I_{max_b}		I_{max_a}	I_{max_a} for 24Vdc output in A for batteries with capacities					
	230Vac	24Vdc	230Vac						
	W	A	W	12Ah	18Ah	22Ah	26Ah	33Ah	45Ah
ZUP-230V-BM-	525	3.0	0				0.21	0.29	
ZUP-230V-BM-	750	3.0	0				0.18	0.26	0.40
ZUP-230V-BM-	1125	3.0	0				0.11	0.21	0.36

Note 1.

The power supplies in the S type housing cannot be equipped with 24Vdc output.

When operating from 230V mains for 400S, -700S and 1000S types, I_{max_a} is 400, 700 and 1000 W according to EN 54-4, and 300, 525 and 1125 W according to EN 12101-10, respectively.

Note 2.

The specified power values for 230V are the determined continuous load power for the table of EN 54-4 (with present mains supply) and for 180s operation for the table of EN 12101-10 for battery energy balance (battery operation, without mains supply).

Note 3.

The I_{max_b} current shown in the tables is limited by the fuse used (see table Basic electrical and environmental parameters).

Note 4.

It is possible to use batteries with other capacities between those indicated in the table. In this case, ask the manufacturer of the power supply to determine the I_{max_a} and I_{max_b} currents suitable for the battery used.

The described conditions are met for operation in the so-called **CSP** mode, in which the PSU works with the control and indicating equipment. This mode of operation is described in more detail in 3.1.

For operation in the so-called **UPS** mode (for a detailed description see 3.2) the conditions of the EN 54-4 standard are met, while the conditions of battery operation can be selected according to the needs of the facility where the power supply is installed.

An example load table for the following battery operating conditions is shown below:

- waiting time (ready to work) 8h;
- operating time at full power 180s;
- current drawn from the 24Vdc output 0.1A;
- 24Vdc output activation time 24h

Based on these assumptions and the required power from the 230V output, the minimum battery capacity can be determined. The conditions imposed by EN 54-4 define the possible load of the power supply at the actual mains supply (see table below).

Power supply type	Battery capacity	according to EN 54-4			
		I _{max_b}		I _{max_a}	
		230Vac	24Vdc	230Vac	24Vdc
ZUP-230V-BM-700M	26 Ah	700 W	2.17 A	700 W	1.11 A
ZUP-230V-BM-1000M	33 Ah	1000 W	2.06 A	1000 W	0.72 A
ZUP-230V-BM-1500L	45 Ah	1500 W	3.0 A	1500 W	3.0 A

The I_{max_b} current shown in the table is limited by the fuse used (see table Basic electrical and environmental parameters).

Basic electrical and environmental parameters.

Power supply	
Mains power supply voltage	230V - 15% +10% 50Hz
Mains current / type of power supply	3.4A/400, 5.2A/700 6.9A/1000, 10.9A/1500
230Vac outputs *1)	
230Vac output voltage - with actual mains supply - in case of no mains power supply *2)	equal to the supply voltage 230V ±10% 50Hz
Short-circuit protection - fuse	10AT 5×20mm
Nominal power / power supply type	400W/400, 700W/700 1000W/1000, 1500W/1500
24Vdc output (option)	
Nominal 24Vdc output voltage *3)	27.1V
24Vdc voltage change range *4): - for ZUP-230V-BM-400 only - the other ZUP-230V-BM types	20.2...28.8V 19.0...28.8V
Maximum ripple value	100mV _{RMS}
Short-circuit protection - fuse	3.15AF 5×20mm
Battery	
Nominal battery voltage	24V
Floating operation voltage at 25°C	27.1 V (2.26 V/cell)
Temperature coefficient of the floating operation voltage	-48mV/°C (-4mV/°C/cell)
Low battery indication	22V
Disconnecting voltage of discharged battery - during active inverter operation (TA time) - out of the time of active inverter operation	18.9...19.9V 20.4V
Maximum battery charging current - battery capacity 12Ah - battery capacity from 18Ah to 45Ah - battery capacity from 50Ah to 75Ah *5)	1.0A 2.0A 2.0A

Current draw from batteries for own use - with the inverter operating - with the inverter switched off - when disconnected from discharged battery	/power supply type 0.59A/400, 0.93A/700, 1.04A/1000, 1.44A/1500 39mA 0.34mA
Maximum additional resistance in the battery circuit Ri max *6)	See table of executions in 1.2 and the settings in 5.8.
Environment	
Operating temperature	-5...+40°C
EN 60529:1991 protection degree	IP 30

*1) The circuits of the mains supply and the 230Vac outputs have a common neutral N wire.

*2) This voltage is not synchronized with the mains supply voltage.

*3) With charged battery at 25 °C.

*4) The range shown includes the voltages between the voltage of the discharged battery (at the end of the battery operating cycle) and the maximum charging voltage.

*5) When using batteries with the indicated capacities, the power supply will not meet the requirements of the EN 54-4 standard regarding battery charging

*6) Designations according to EN 54-4+A1+A2

Compliance with standards

Electrical safety	EN 62368-1:2014 + A11:2017 class I
Functionality	EN 54-4:1997 + AC:1999 + A1:2002 + A2:2006; EN 12101-10:2005 + AC:2007
Functional class	EN 12101-10:2005 + AC:2007 class A
Environmental class	EN 12101-10:2005 + AC:2007 class 1
EMC immunity	EN 50130-4:2011 + A1:2014
EMC emission	EN IEC 61000-3-2:2019 EN 61000-3-3:2013 EN IEC 61000-6-3:2019

The power supply meets the requirement of the regulation of the Minister of the Interior and Administration of 20 June 207 (Journal of Laws, No. 143, item 1002), with the amendment of 27 April 2010 (Journal of Laws, No. 85, item 553).

In addition, the power supply meets the requirements of the Regulation (EU) 305/2011 of the European Parliament and of the Council of 9 March 2011. (CPR – Construction Products Regulation).

2. Construction and principle of operation of the power supply

The ZUP-230V-BM power supply includes: the ZUP-BM control module, a 24Vdc/230Vac inverter, a 24V battery and a rectifier. The power supply can operate in one of two modes: CSP and UPS. The selected operating mode defines the specific characteristics and behavior of the power supply. This is explained in more detail later in this manual.

The ZUP-BM module is responsible for charging the battery and supervising its status, receiving control signals, making decisions on switching the power supply sources and performing functions related to gate control.

With the actual mains supply, the inverter operates all the time, but with no load on its output. This makes it possible to monitor its condition and indicate any damage.

In CSP mode, after a mains power failure, the inverter acquires the output power supply and after a set time is switched off to save battery power. When a control signal (fire alarm) occurs, the inverter is switched on and supplies the receivers for a set period, after which it is switched off again.

In UPS mode, after a mains failure, the receivers are switched to inverter power and operate until the battery reaches end-of-discharge voltage, after which the inverter is switched off. In this mode it is also possible to remotely control the switching on and off of the inverter using the **DO** input.

The battery backs up the PSU in case of mains power failure. Its capacity depends on the power of the inverter and the number of operated gates.

The 230Vac/24Vdc rectifier charges the battery, keeps the inverter operating with the actual 230V mains supply and allows the power supply of additional receivers connected to the optional 24Vdc output.

A simplified diagram of the power supply is shown below.

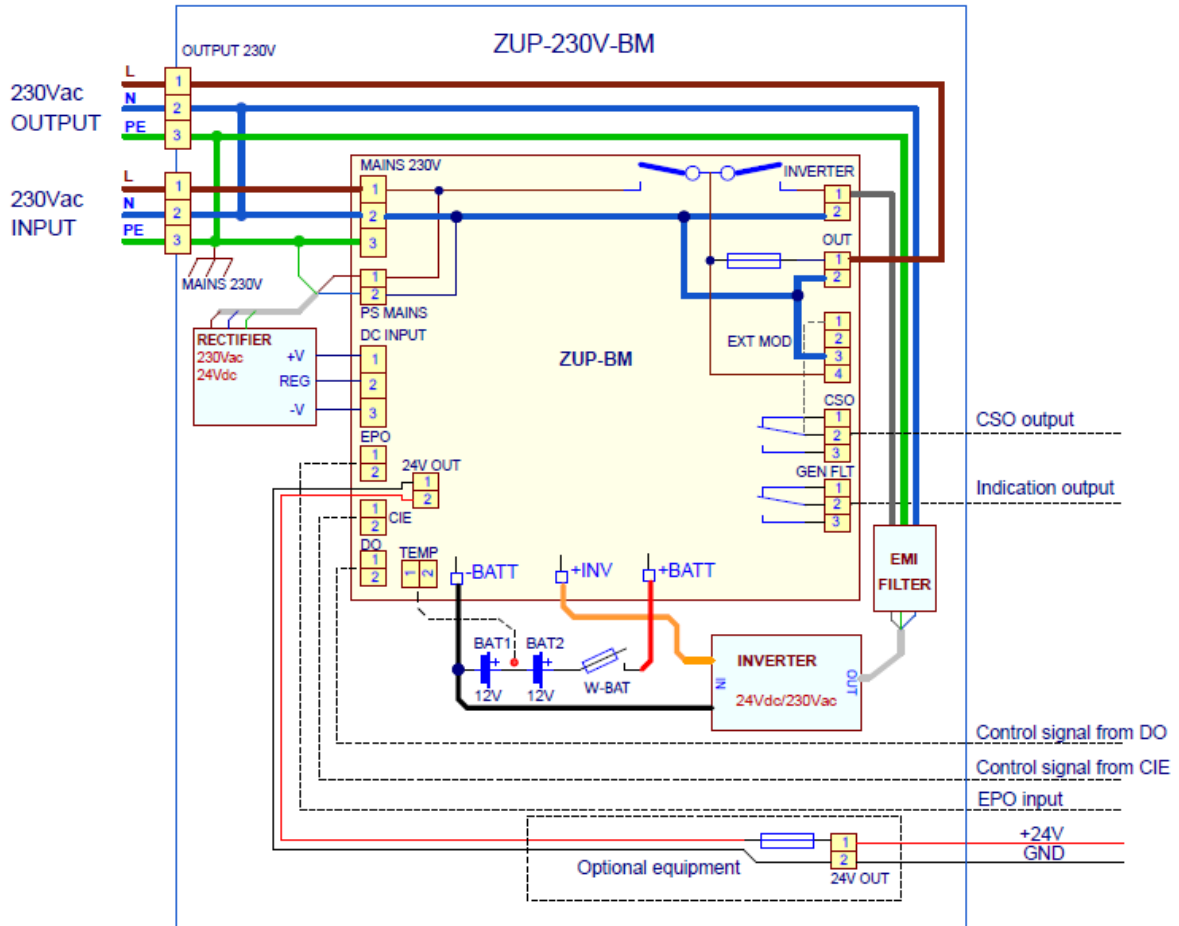

Fig. 2. Simplified diagram of connections of the ZUP-230V-BM power supply.

For the user, there is a fused 230Vac power supply output of the gate **OUT** and relay indicating outputs **GEN FLT** and **CSO**.

Via the **GEN FLT** output (collective fault signal) the power supply indicates:

- 230V mains power failure,
- inverter damage,
- high resistance of the battery circuit,
- low battery voltage,
- configuration error of a control input from CSP,
- rectifier damage,
- temperature probe damage,
- tripping of the EPO input.

Depending on the selected operation mode, the **CSO** output triggers gate opening or acts as an additional PSU status indication.

The power supply has two control signal inputs **CIE** and **DO**. Their function depends on the selected operating mode.

The main feature that distinguishes CSP mode from UPS mode is the way the voltage is supplied to the **OUT** output and the control of the **CSO** output, as well as the way the

signals from the **CIE** and **DO** inputs are received. However, in both cases, 230Vac mains voltage is supplied to the **OUT** output when mains power is present.

Accessory equipment of the **ZUP-230V-BM** power supply:

ZUP-230V-BM-24V - a module enabling to supply external devices which require uninterruptible 24Vdc voltage.

The module includes a connector for mounting on a TS-35 bus together with a fuse. Voltage is supplied from the rectifier and, in the event of a mains power failure, from the battery. Maximum load of this output depends on the particular type of the ZUP-230V-BM power supply and its operation mode (see table of technical data in 1.2).

ZUP-TR - programmable relay module enabling additional time functions.

The ZUP-TR module contains a relay, designed for mounting on a TS-35 rail, equipped with a potential-free output with a load capacity of 10A/230Vac and 10A/24Vdc, which can be controlled from both 24Vdc and 230Vac. In addition to the relay, additional elements are supplied: connecting cables, connectors, single-circuit connectors, etc.

The relay can be used, for example, to extend the time of switching the power supply from the mains to the battery or vice versa (in this manual it is the T_DLY time) when the power supply unit cooperates with controllers requiring a long break between the power failure and return.

If it is necessary to use this relay, it is required to contact the manufacturer of the power supply in order to agree on detailed electrical and assembly requirements.

2.1. Operation in CSP mode for air gates

The CSP mode is designed to work with the output of the CIE (Control and Indicating Equipment) or the output of its wire module. Receiving a fire alarm signal through the **CIE** input causes control of the relay at the **CSO** output, which, through the gate controller, causes opening of the gate. In the event of a mains power failure, the voltage is switched off at the **OUT** output after a set **TS** time of the inverter. Only when the control signal appears, it restarts the inverter, which supplies the **OUT** output and then, with some delay, the relay at the **CSO** output is controlled. The delay enables the operating conditions of the controller to settle down so that the controller can accept this signal.

The **DO** control input functionally works in the same way as the **CIE** input. The differences concern their purpose and the way they are connected. The **CIE** input is designed to work with CIE and the way it is connected can be configured. The **DO** input only enables to connect an additional manual push button to open the gate by closing its terminals.

The **DO** input should not be used for normal daily gate operation. In the absence of mains power, this can lead to discharging of the batteries and incorrect operation of the PSU in the event of a real emergency. The manual gate opener button connected to this output should be treated in the same way as the fire alarm buttons, i.e. it should be protected against accidental or unauthorised use. Restoration to normal operation requires it to be reset and re-secured. If the **DO** input is left in the ON (closed) state, in any situation where the **CSO** signal has already been switched off, the appearance of a fire alarm at the **CIE** input switches it on again

Note.

For the factory settings, voltage is always present at the **OUT** output when mains power is present. In the absence of mains power, battery operation lasts only a specified time.

For more information on the electrical parameters for the CSP mode, please refer to the technical data table in 1.2. The time dependencies for this mode are presented in 3.1

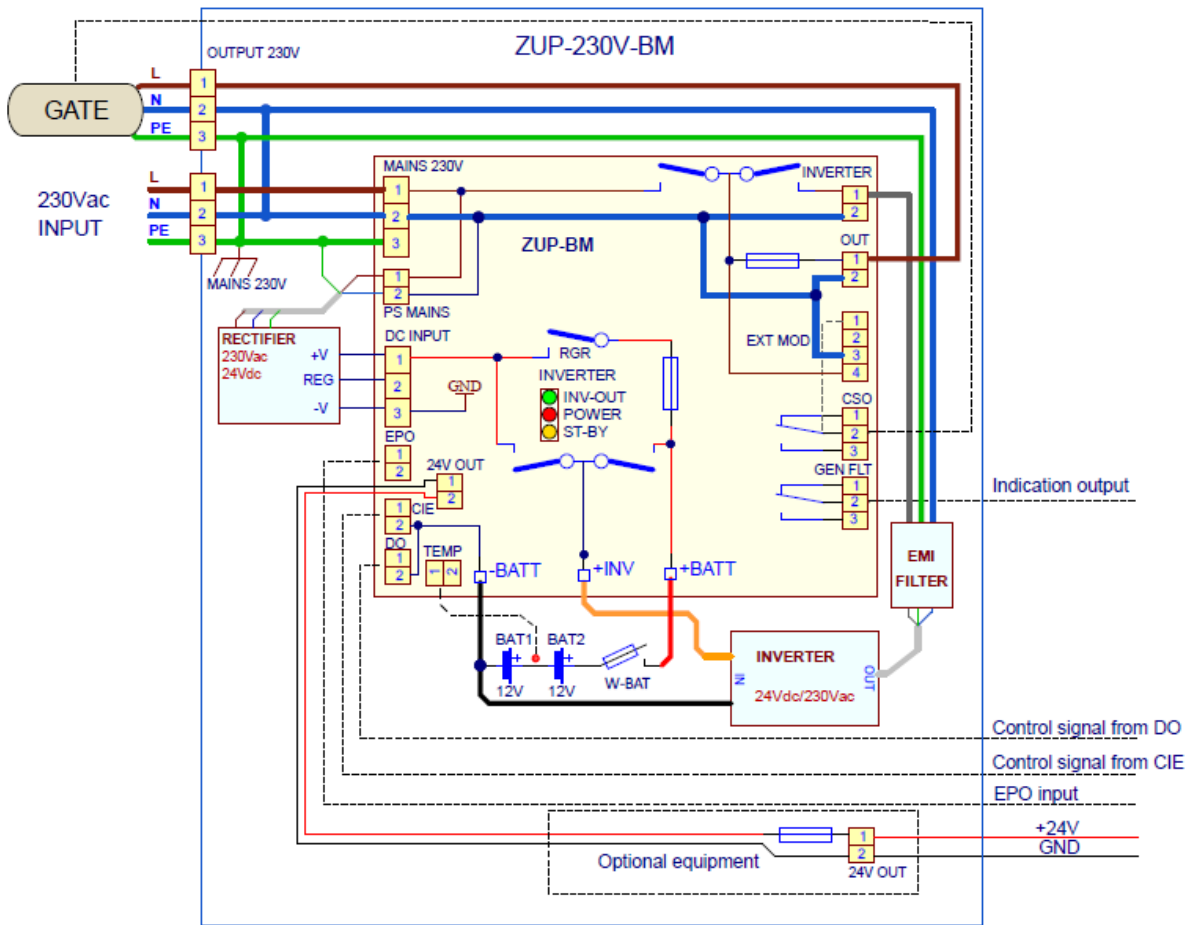

Fig. 3. ZUP-230V-BM connection diagram for CSP mode.

DO - Manual opening of the gate. Digital input active by closing the terminals.

CIE - signal input from CIE or wire module output. It can be configured as a digital input with wire resistance monitoring. For digital inputs it will be respectively closing and opening of the terminals and for operation with wire control, low and high resistance (see Power supply configuration).

CSO - relay output. In CSP mode, the **CSO** output is responsible for triggering the gate opening by closing the corresponding input in the gate controller. Continuous or cyclic operation can be set, with repeated pulses triggering the gate opening. The function of this output can also be changed to indication of 230V mains power failure.

EXT MOD – connector for connection of expansion modules.

2.2. Operation in UPS mode

The UPS mode only provides voltage backup to the **OUT** output after a mains power failure (see 3.2). The backup time is limited only by the capacity of the batteries used and the actual load. In this mode, the inverter operation is controlled by the **DO** input. Through this input, the inverter can be remotely switched off and on again. The **CIE** input is inactive in this mode of operation.

For more information on the time dependencies for UPS mode, see 3.2 and 5.8.

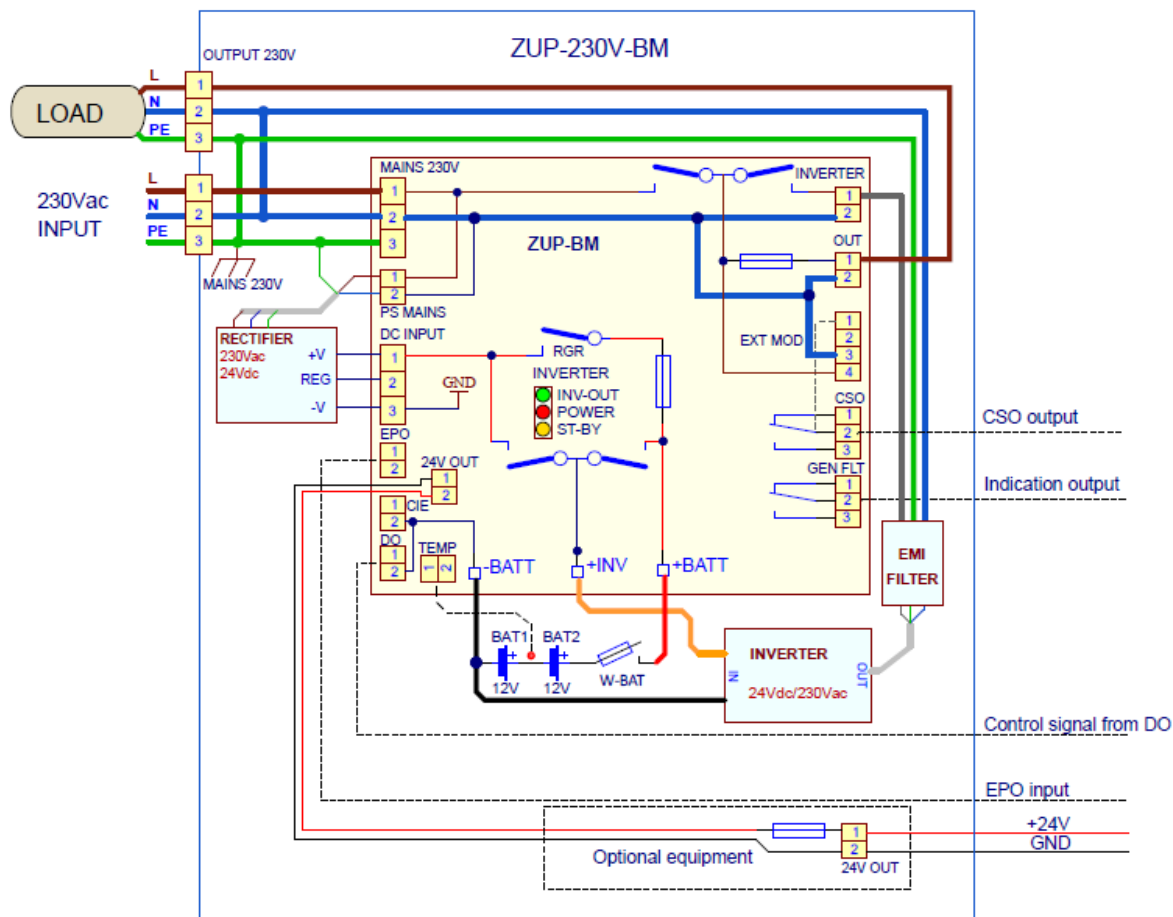

Fig. 4. ZUP-230V-BM connection diagram for UPS mode.

DO - Signal of resuming or shortening the operation time. Digital input active by closing the terminals.

CSO - relay output. In UPS mode, the **CSO** output is responsible for indication of low battery voltage. This function can be changed to indication of 230V mains power failure.

2.3. EPO circuit breaker

An EPO (Emergency Power OFF) circuit breaker can be connected to the power supply.

Note.

The EPO circuit breaker may only be used when operating in UPS mode. Operation of the power supply in the CSP mode, i.e. as a fire protection device, excludes such a possibility.

Its use causes a **complete shutdown of the power supply**: disconnection of the 230V output and the 230V mains supply as well as disconnection of the internal inverter from the battery. The disconnection concerns only the L wire of the 230V supply system. The N wire between the mains input and the PSU output remains connected. In this state only the power supply controller and its status indication remain active.

The purpose of the mains disconnection relay is to protect against backfeed - . voltage appearing in the mains circuit as a result of the operation of the inverter in the power supply.

The power supply enables selection of the operation mode of the EPO signal input: by opening or closing the terminals - see pos. 9 in the table describing the setting of the slide switch in 5.8.

Restoring the power supply to operation, apart from switching off the EPO signal, requires a reset of the power supply with the **RUN** button. If this input is not used, the terminals of this input must be necessarily closed and the slider no. 9 of the **SETTINGS** switch set to the ON position.

3. Detailed description of the power supply operation

A table of detailed setting ranges for **CSP and UPS** mode is provided in 5.8. A description of the time designations used in Figures 5 to 13, together with their values, is presented in the table below.

TA	9 min	inverter operating time triggered by a fire alarm
TS	9 min	inverter operating time triggered by mains power failure
T_DLY	25ms/2s	mains to battery and battery to mains supply switching time
T_MR	5s	delay in switching to mains (required time of stable mains)
T_INV	max 10s	inverter start-up time
T_CIE	2s	time of recognition of the control signal at the inputs (minimum duration)
T_CSO	2s/12s	gate opening delay

Each switching of the power source is associated with a loss of the output voltage for the **T_DLY** time. There is a choice of two values for this time: 2s or 25ms.

Switching from battery to mains supply can only take place when the 230V mains voltage has been present and stable for the **T_MR** time (5s). This function protects the power supply against the connection of unstable mains voltage.

The presence of a control signal at the **CIE** or **DO** inputs for a minimum of 2s (**T_CIE** time) is required to eliminate false alarms and disturbances. A too short or unstable signal will be ignored.

There are two values of gate opening delay time to choose from: 2s or 12s.

3.1. CSP mode

The voltage at the **OUT** output when the mains supply is present is always present. The inverter operates during this time for control purposes only.

In the event of a mains power failure, the voltage is switched off at the **OUT** output after a set **TS** time of the inverter. Giving a control signal to the **CIE** or **DO** input activates the power supply for **TA** time (9min), during which the inverter supplies the **OUT** output.

The **CIE** input is dedicated to operate the fire automation signal, hence it can be supervised, the **DO** input is dedicated to connect a manual gate opener button.

The figures below present basic situations of the power supply operation in the CSP mode, in which the voltage backup at the **OUT** output has been set to continue with the present mains supply, in spite of the termination of a fire alarm (the **H** sliding switch in the ON position, see the table in 4.).

Setting the **H** switch to OFF position will switch off the voltage at **OUT** output after **TA** time (simultaneously with **CSO** signal disappearance) both in case of the present mains supply and battery operation. This is intended to improve safety during firefighting operations.

Thus, the occurrence of a fire alarm will trigger a certain action of the power supply only once. A second or subsequent alarm signal will have no effect. Return to normal operation after the above-mentioned action and restoration of the voltage at the **OUT** output requires a reset of the power supply by pressing the **RUN** button (see the table in 4.0.).

The **CSO** output can operate in two ways (see table in 4.0.):

- give a continuous gate-opening signal;
- cyclically repeat the pulses that trigger the opening of the gate.

The second way can be used by some gate controllers to automatically resume its movement if the gate is temporarily mechanically blocked, or stopped by a button on the control panel.

Fig.5 (below) Return of mains power and appearance of fire alarm with 230V mains power present.

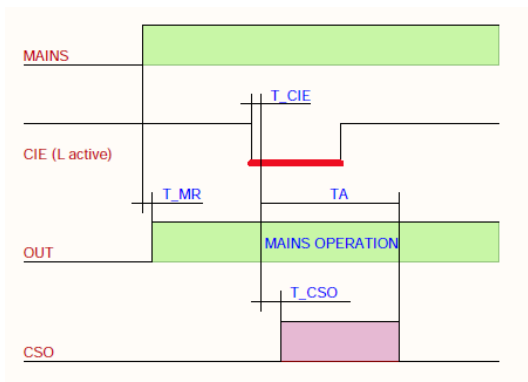

In the stand-by state (without fire alarm) the appearance and then the persistence of a stable **MAINS** supply for a **T_MR** time causes the power supply to switch to the **OUT** output.

If a signal appears on the **CIE** input at the present mains supply and is maintained for the **T_CIE** time, a countdown of the **TA** and **T_CSO** times will be started. After the countdown of **T_CSO** time, the **CSO** relay is excited, triggering the opening of the gate. With the end of the **TA** time countdown, the **CSO** relay is switched off.

Fig.6 (below) 230V mains power failure and appearance of a fire alarm in the absence of mains power.

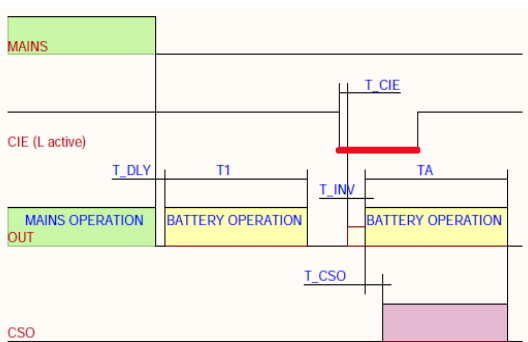

In the event of a mains power failure, a switchover to battery power takes place after **T_DLY** time for a set **TS** time.

If there is a signal on the **CIE** or **DO** input present for a **T_CIE** time, the inverter is activated. After **T_INV** time (time required for inverter start-up), the voltage at the inverter output appears and the countdown of **TA** and **T_CSO** times starts. After the countdown of **T_CSO** time, the **CSO** relay is excited, triggering the opening of the gate. Then, after the **TA** time has passed, the

inverter and the **CSO** relay are switched off.

Fig.7 (below) Appearance of a fire alarm during battery operation caused by 230V mains power failure.

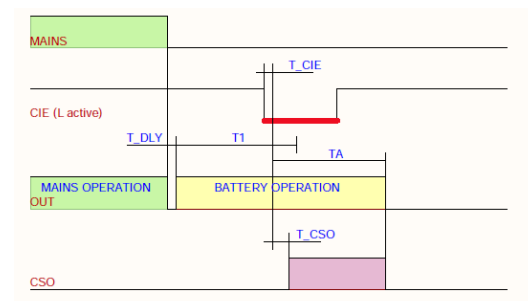

The detection of a fire alarm at the **CIE** input during battery operation (triggered as in the description to Fig.6.) causes the interruption of the **TS** time countdown and the start of the **TA** and **T_CSO** time countdown. Then, as before, after the countdown of the **T_CSO** time, the **CSO** relay is excited, triggering the opening of the gate. Then, after the **TA** time has passed, the inverter and the **CSO** relay are switched off.

Fig.8 (below) 230V mains power failure during the **TA** operation triggered by a fire alarm.

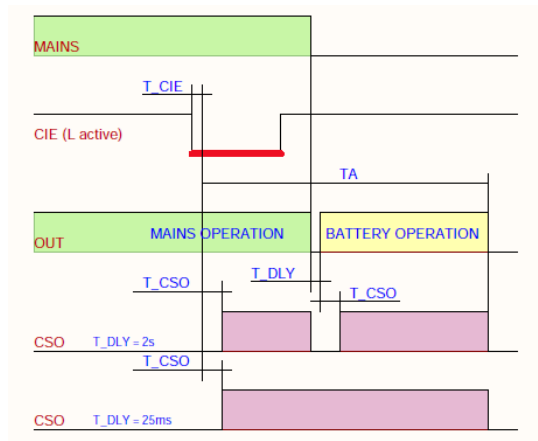

230V mains power failure during **TA** time countdown forces switching to battery supply with momentary power failure at the **T_DLY** time.

The behaviour of the **CSO** relay, previously switched on after recognition of the **CIE** signal, depends on the setting of the **T_DLY** time (switching time of the power source).

For a set long break time (2s), the **CSO** relay is switched off together with the mains power failure and switched on again, after switching to battery operation, with the **T_CS0** delay. This behaviour is compatible with the gate controllers, which do not tolerate even short power outages, after which they need to be reset and restarted -

to continue opening the gate.

Gate controllers that are able to ignore the short break time (25ms) do not require a reset and restart operation. In this case switching on of the **CSO** relay is maintained despite a change of the power source.

Fig.9 (below) Return of 230V mains supply during battery operation caused by mains power failure.

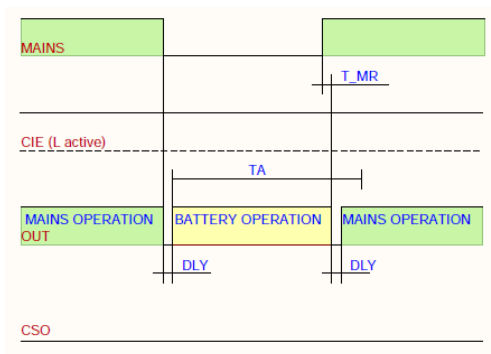

Detection of **MAINS** stable mains supply at **T_MR** time interrupts the **TS** time countdown (see description to Fig.6.), ends battery operation and with a delay of **T_DLY** restores mains supply to the **OUT** output.

Fig. 10a. (below) Return of 230V mains supply during battery operation triggered by a fire alarm, with interruption of battery operation.

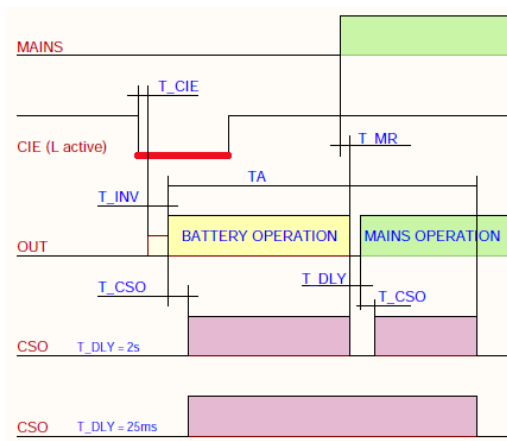

If battery operation is allowed to be interrupted when the mains supply returns (see 4. Description of ZUP_BM board, switch B), switching to mains supply takes place as soon as the stable mains is detected at the **T_MR** time. In this case, after the **TA** time is counted down, only the **CSO** relay is switched off.

The detailed way of switching to the mains power supply including the operation of the **CSO** relay is included in the description to Fig.8.

Fig. 10b (below) Return of 230V mains supply during battery operation triggered by a fire alarm, without interruption of battery operation.

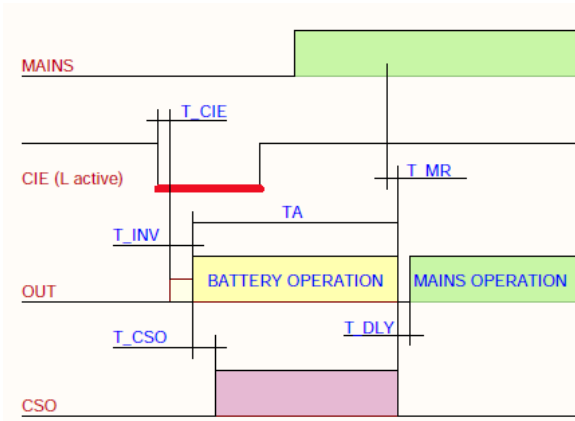

If the possibility of interruption of battery operation on return of the mains voltage is disabled (see 4. Description of ZUP_BM board, **switch B**), in spite of its return in **TA** time, the switching to the mains voltage takes place as soon as this time has passed, provided that the mains voltage was sustained before that time longer than the **T_MR** time and additionally only after the **T_DLY** break time.

The CSO relay is switched off at the end of the **TA** time countdown.

If, however, the battery is discharged during battery operation, the switchover to

mains operation will take place immediately, as indicated in the description to Fig.10.a above.

3.2. UPS mode

In this state, the voltage on the **OUT** output is always present when the 230V network is present. The **CIE** input is inactive.

The way the device operates depends on the setting of the switch no. 4 in the **CI** section defining the operation of the **DO** input (see 5.8 Power supply configuration). For battery triggered operation (switch in OFF position) it is recommended to use a monostable switch (e.g. a button). A bistable switch should be used for battery static operation (switch in ON position).

For slider switch no. 4 set to OFF (triggered switchable battery operation), a switchover to battery operation takes place as soon as a mains power failure is detected. At the **OUT** output after the **T_DLY** time a voltage of 230V from the inverter appears. In this state, appearance of a low state at the **DO** input causes switching off of the inverter (230V voltage failure at the **OUT** output). Each reappearance of the low state on the control input changes the operating status of the inverter - it turns it on if it was previously off, or turns it off if it was previously on. With the mains supply present, the **DO** input is inactive.

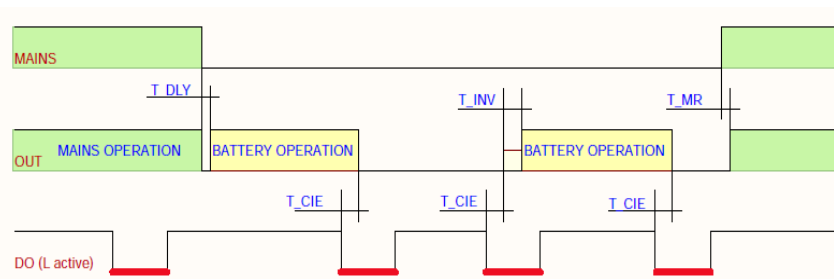

Fig.11 UPS mode: switch operation.

In case of the slide switch no. 4 set in the ON position (static battery operation, switched on) at the moment of detecting the mains power failure, the battery operation is switched (switching of the **OUT** output to 230V voltage from the inverter after the **T_DLY** time) provided that the **DO** signal is active. This voltage is maintained as long as the signal at the **DO** input is active. When no active signal is detected at the control input, the inverter operation is switched off. The inverter can be switched on again when an active state is given to the **DO** input.

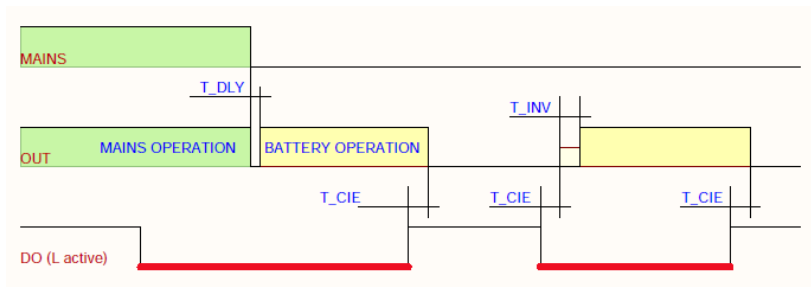

Fig.12 UPS mode: static operation.

The return of a stable voltage from the mains (for the **T_{MR}** time) causes the **OUT** output to switch to the mains regardless of the state of the **DO** input. If an active state was maintained on the **DO** input before the mains power returned and the **OUT** output was connected to the inverter voltage, the output from the inverter will be switched to the mains.

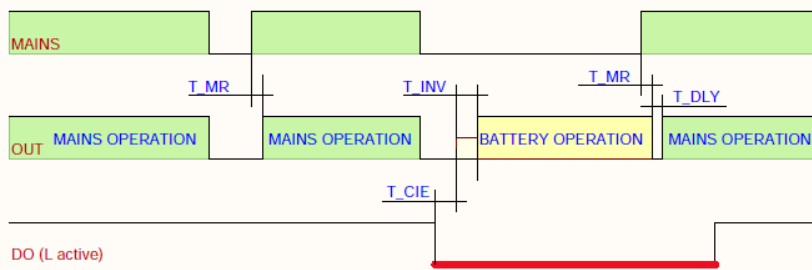

Fig.13 UPS mode: static operation cont.

Start-up of the inverter in the absence of mains power and its continued operation depend on the state of charge of the batteries.

4. Description of ZUP-BM board

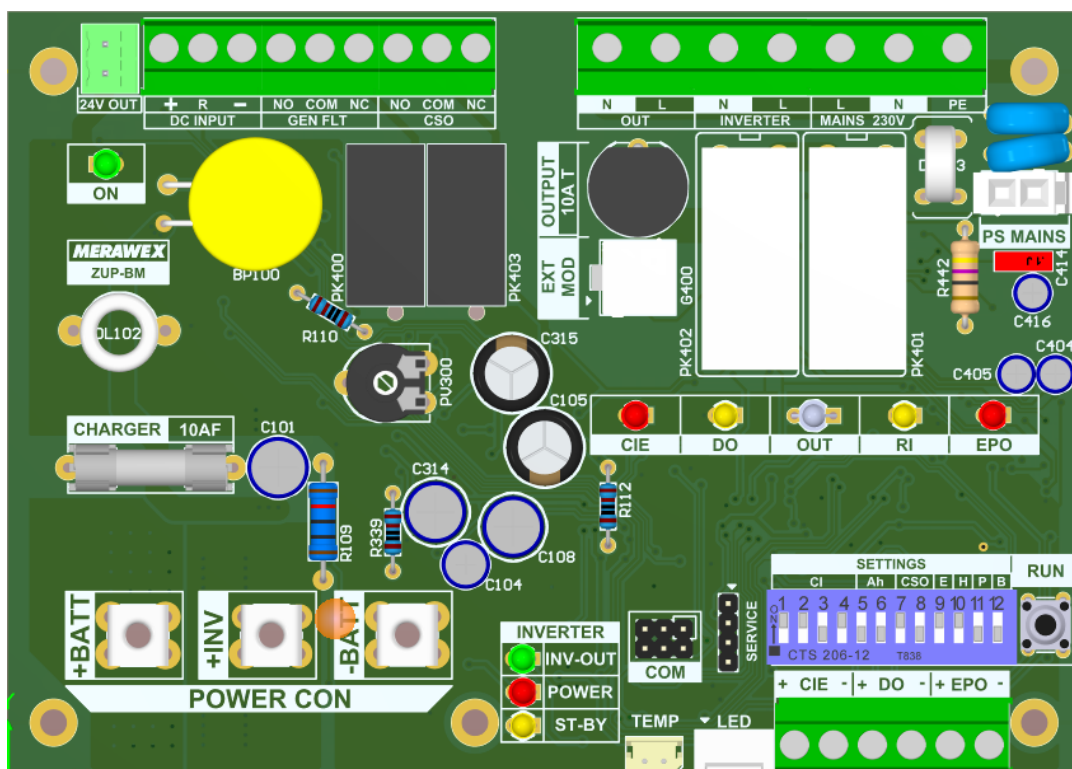



Fig. 14. View of ZUP-BM board.

Description of elements of ZUP-BM board.

In the **Designation** column, the full English words from which the acronyms were derived are entered.

Designation	Function description
Connectors on ZUP-BM board	
MAINS 230V <i>MAINS 230V</i>	230Vac mains power input.
INVERTER <i>Inverter</i> *1)	Power input from 230Vac inverter.
OUT <i>Output</i>	Power output 230Vac.
PS MAINS <i>Mains Power Supply</i> *1)	24Vdc rectifier mains supply connector.
CSO <i>Control Signal Output</i>	Relay output of the control signal. NO and NC contacts are available. The excitation status of the relay is indicated by a yellow LED mounted at the edge of its base.
SERVICE <i>Service</i>	Service connector (do not connect!).
COM <i>Communication</i>	Digital communication connector (do not connect!). Only for the manufacturer's use.
TEMP <i>Temperature probe</i> *1)	Temperature probe connector.
GEN FLT <i>General Fault</i>	Fault relay indication (see description of FAULT LED). The output is a collective fault signal. NO and NC contacts are available. It operates with a delay of 5s in case of mains power failure. The excitation status of the relay is indicated by a yellow LED mounted at the edge of its base.
CIE <i>Control and Indicating Equipment</i>	Control signal input from Control and Indicating Equipment - the alarm state must last longer than 2s; the method of operation is described in 5.8
DO <i>Open Doors</i>	Non-parameterised signal input for manual gate opening in CSP mode and inverter on/off in UPS mode.
EPO <i>Emergency Power Off</i>	Control signal input from safety switch.
DC INPUT <i>DC Input</i> *1)	24Vdc power input.
24V OUT <i>24V OUT</i>	Connector for connection of 24Vdc output module of ZUP-230V-BM-24V
+INV <i>Inverter</i> *1)	Positive bus of the inverter power supply.
+BATT <i>Battery</i> *1)	Positive terminal of the battery.
- BATT <i>Battery</i> *1)	Negative terminal of the battery.
RUN button	
RUN <i>Run</i>	A short press on the button provides: - resetting the power supply after its switching off by the signal from the EPO input; A button pressed for more than 2s resets the EPO function and additionally enables: - reduction of the TA time (time of operation triggered by a fire alarm); - starting the power supply from a battery; - checking the functionality associated with the selected mode;

	- in the CSP mode, resetting the power supply after an action triggered by a fire alarm (see 3.1) only with H slider of the SETTINGS switch in the OFF position
--	---

LED indication on ZUP-BM board		
ON <i>On</i>	Green	Board power indication
INVERTER POWER <i>Inverter Power</i>	Red	Indication of connection of the inverter directly to the battery.
INVERTER ST-BY <i>Inverter Stand By</i>	Yellow	Inverter back-up indication. Inverter powered by 230Vac/24Vdc rectifier
INVERTER INV-OUT <i>Inverter Out</i>	Green	Inverter operation indication.
CIE <i>Control and Indicating Equipment</i>	Red	Fire alarm indication - off: no alarm or UPS mode operation - lit: a fire alarm has occurred (also when using the RUN or DO button); - flashing: a fault has been detected on the fire alarm input wire from the CIE; - short flashes - correct CIE wire status
DO <i>Open Door</i>	Yellow	Indication of active state on DO input.
OUT <i>Output</i>	Green	OUT output connected to mains
	Yellow	OUT output connected to inverter
	Turned off	No voltage at the OUT output
RI <i>Battery Circuit Resistance</i>	Yellow	Battery fault indication
EPO <i>Emergency Power Off</i>	Red	Indication of the tripping of the EPO circuit breaker
LED indication on the door of the ZUP-230V-BM power supply cabinet		
MAINS <i>Mains</i>	 Green	Power status: - lit: mains supply present; - flashing: battery operation (no mains supply) - off: no power supply, battery disconnected
FAULT <i>Fault</i>	 Yellow	Fault indication: - 230V mains power failure, - inverter damage, - high resistance of the battery circuit, - low voltage of 22V battery (only during battery charging) - configuration error of a control input from CIE, - rectifier damage, - temperature probe damage, - tripping of the EPO input.
SETTINGS slide switch (detailed description in 5.8.)		
CI <i>Control and Indicating</i>		Setting the mode and method of operation for the power unit
Ah <i>Ampere Hours</i>		Choice of battery capacity

CSO <i>Control Signal Output</i>	Setting the method of operation for the CSO output
E_{PO} <i>Emergency Power Off</i>	Setting the method of operation (active state) for the EPO input
H_U <i>Hold Up</i>	Maintaining voltage on the OUT output after a fire alarm from the CIE input
P <i>Pulse</i>	Method of gate opening activation by CSO output
E_{BO} <i>End of Battery Operation</i>	Method of terminating battery operation when the mains power returns (for CSP mode only).

*1) Connections made by the power supply manufacturer.

5. Installation

5.1. General notes

The place of installation of the power supply should be selected in such a way as not to expose it to mechanical damage and not to exceed the acceptable parameters of temperature and air humidity. If possible, the power supplies should be installed in fire-separated rooms (e.g. electrical switchboards, technical rooms, cable shafts, etc.).

A small cabinet (S type) should be fixed directly to the wall through 3 holes in its back wall, whereas a medium and a large power supply cabinet (types M and L) can be fixed directly to the wall through 4 holes in its back wall or using four distance brackets.

The location of the fixing holes is shown in Fig.1. Metal screw anchors should be used for installation (M6 anchors are recommended due to the mounting holes provided). Screw anchors made of PVC must not be used.

When assembling a medium or large cabinet with direct use of the rear panel openings, it is advisable to first remove the inverter by unscrewing the two nuts at its bottom, tilting it slightly and sliding it downwards.

Due to its weight and dimensions, the battery should be placed in the cabinet last, after all cable connections have been made.

Note.

The selection of cables in power supply and control systems for fire protection devices should take into account Art. 187 of the Regulation of the Minister of Infrastructure of 12 March 2009 Dz. U. /Journal Of Laws/ No. 56 item 461 on technical conditions to be met by buildings and their location, as amended. Consolidated text of the Ordinance of the Minister of Infrastructure of 7 June 2019 item 1065.

5.2. Connection of mains supply

The mains supply cable with a minimum cross-section of 3×1.5mm², after being fixed in the gland, should be led through a large arc before it is fixed by the cable holder and connected to the corresponding terminals of the ZUP power supply. The outer insulation of the cable (tyre) should be removed directly behind the cable clamp.

Note: It is absolutely necessary to identify the L wire of the mains supply and to connect it properly to the L terminal of the ZUP-230V-BM feeder (MAINS 230V connector, L terminal).

The connection of the mains supply must be made as a permanent installation with continuity of the neutral wire (N). The installation switch described below must be in the live wire (L).

The power supply is not equipped with its own mains circuit breaker, so a special installation breaker is required outside the power supply. Such a circuit breaker should also

perform the role of an overload and short-circuit protection and allow to power devices with a high starting current. It is recommended to use the S301 C16A installation circuit breaker. Such a circuit breaker should be clearly marked as being used in the fire protection system and must not be used in other circuits at the same time.

Warning.

Connecting the mains using the switch located outside the power supply can be done only with fully assembled internal wiring of the power supply, including the inverter correctly connected and mounted.

It is forbidden to leave the 230Vac power plug disconnected from the inverter output.

5.3. Connection of 230Vac circuits

The wires for external connections should be routed through the selected openings in the cabinet body (after removing the blanking plugs) and fixed by twisting the appropriate cable glands. The wires which are to be led to the output (and outputs of optional expansion modules) after fixing them in the glands should be led through a large arc before they are fixed by cable holders and connected to respective terminals of the ZUP power supply. The outer insulation of the cable (tyre) should be removed directly behind the cable clamp. A 3-core HDGs 1.5mm² cable is recommended for making connections of 230Vac power supply systems in fire protection systems. For devices of insulation class II, it is possible to use 2-core cables without connection to PE bus.

Only one consumer device can be connected to the **OUT** output on the ZUP-BM board of the power supply. It is necessary to pay attention to the nature of load carried by some receivers. For example, induction motors can consume considerable current at start-up that can lead to blowing of the fuse placed at the given output or prevent correct start-up of the inverter.

5.4. Connecting the battery

The battery, placed with its terminals on the door side of the housing, must be connected using the two wires already brought out from the power supply, paying particular attention to the correct polarity: red wire to the positive terminal of one battery, black wire to the negative of the other battery. Finally, connect the two batteries to each other using the cable (connector) supplied by the manufacturer.

NOTE: The power supply is not protected against reverse connection of the battery. Incorrect connection may lead to destruction of the power supply.

The battery should be connected with the battery disconnecter switched off and its fuse link removed.

All connections should be made carefully, bearing in mind that during battery operation (when the mains supply is off) the current drawn by the inverter may reach 90A.

For correct temperature compensation of the battery floating operation voltage, the temperature probe should be placed between the sides of both batteries.

5.5. Emergency operation with one power source.

The power supply should work with both power sources connected:

- primary, mains;
- backup, battery.

However, it is possible to run the power supply in an emergency when only one power source is present, which will, for example, allow the gate to be operated, but will not ensure that the primary function -of providing a guaranteed power supply is fulfilled.

Below, there is an indication of the operational status of the ZUP-230V-BM power supply in case of connection of both power sources (mains and batteries) or only one of them. Start-up of the power supply from the mains is automatic. In case of lack of the mains power supply, the **RUN** button should be pressed (see 4).

The table shows the operation of the power supply in CSP mode. Notes under the table indicate differences specific to UPS mode.

Operation indications in case different power sources are connected			battery and mains	only battery	only mains
LED indication - cabinet door					
MAINS	green	Mains supply status.	turned on	flashes	turned on
FAULT	yellow	Fault indication.	turned off	turned on	turned on
LED indication - ZUP-BM board.					
ON	green	Board supply status.	turned on	turned on	turned on
INV-OUT	green	Inverter operation indication.	turned on	turned on	turned off
POWER	red	Inverter connected directly to the battery.	turned off	turned off	turned on
ST-BY	yellow	Inverter in stand-by mode (supplied by rectifier)	turned on	turned off	turned off
CIE *)	red	Indication of the confirmation of a fire alarm.	short flashes	short flashes	short flashes
DO **)	yellow	DO input active state	turned off	turned off	turned off
OUT	green	Mains voltage present at OUT output	turned on	turned off	turned on
	yellow	Voltage from the inverter present at the OUT output	turned off	turned off **)	turned off
RI	yellow	Battery fault indication.	turned off	turned off	turned on
EPO *)	red	Indication of the tripping of the EPO circuit breaker	turned off	turned off	turned off
Relay indication					
GEN FLT	Fault indication <i>The excited state indicates no damage.</i>		excited	not excited	not excited
CSO	Control signal output.		not excited	not excited	not excited

*) The indicated LED state corresponds to the absence of an active state at the **CIE** input. Its short flashes additionally indicate the correct state of the **CIE** wire (see table in 4.). In UPS mode, the **CIE** input activity indication is off.

) In UPS mode with switch operation, the **DO input activity indication lights up. In this mode, with battery power only, the **OUT** output is supplied with voltage from the inverter, so the **OUT** LED lights up yellow.

Yellow LEDs are mounted near the bottom edge of the housing of both indicating relays. Their lighting indicates the state of excitation of the respective relay.

5.6. Connection of control inputs

The **CIE** input (confirming the fire alarm signal from the CIE) can operate with parameterisation or as a binary input. However, in both cases it is required that the parameters of the control circuit are within certain defined limits:

- for input with parameterisation, resistance values including connection resistance and leakage resistance (between wires) must not differ by more than 10% from the required value of 1kΩ and 10kΩ
- for binary input the short circuit resistance must not be higher than 1kΩ and the leakage resistance (between wires) must not be lower than 100kΩ.

If these values are exceeded, the power supply sets the **GEN FLT** error indication.

The **DO** and **EPO** inputs, unlike the **CIE** input, are not supervised (no parametrization). They are binary inputs responding to short-circuit and open terminals.

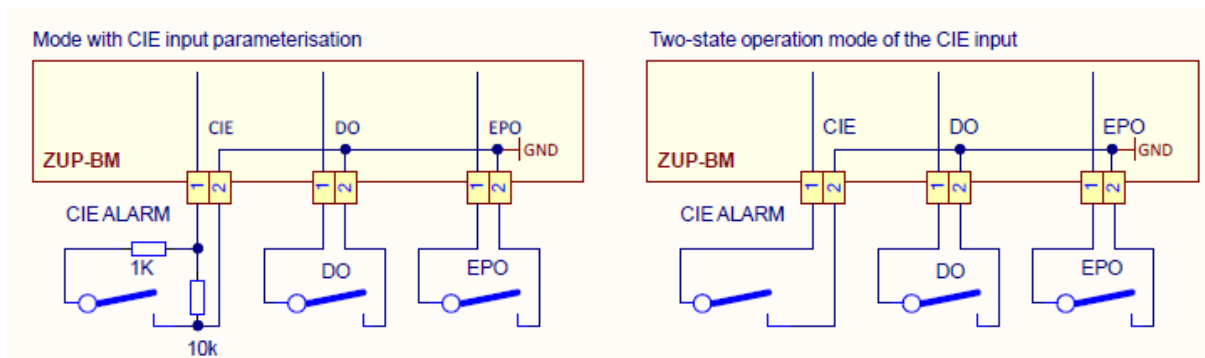

Fig.15 Connections for the **CIE** fire alarm input, **DO** gate opener button and **EPO** circuit breaker.

5.7. First start-up

5.7.1. Starting the power supply in CSP mode.

The power supply start-up process described below refers to start-up using the factory settings described in 5.8. It is recommended that the first start-up be performed by service personnel trained by the manufacturer. In case of a different PSU configuration than the one resulting from the factory settings, some items will look different. The presented process assumes correct operation of all elements. In case of any discrepancies, please refer to the appropriate descriptions included in the operational manual or contact the manufacturer's service to clarify any doubts.

Initial state:

- mains power disconnected by the installation switch (outside the power supply);
- terminals of the batteries are not connected and, additionally, the batteries are disconnected by the circuit breaker inside the power supply (marking on the diagram: W-BAT)
- if no gate controller is connected to the **OUT** output, any receiving device (voltage indicator, bulb, motor, etc.) should be connected in its place;
- if no gate controller is connected to the **CSO** output, e.g. an ohmmeter or other tester will be needed to check the relay status on this output;
- if no receiver for this signal is connected to the **GEN FLT** output (e.g. fire panel), e.g. an ohmmeter or other tester will be needed to check the relay status on this output;
- check the configuration of the **SETTINGS** switch, which should be in accordance with the factory settings (see figure below);

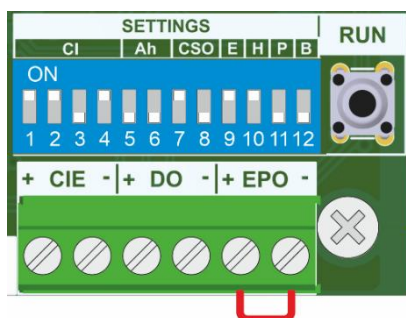

The setting of the **Ah** section (sliders 5 and 6) should correspond to the specific type of power supply being activated, and the battery used (see tables in 5.8.)

- resistors parameterising this wire should be connected to the **CIE** input as shown in Fig. 15. with the 1kΩ resistor circuit being open (no fire alarm);

- the **DO** input should be left unconnected and, if it is to be used, the switch connected to it should be opened (no forced opening of the gate);
- a jumper should be placed on the **EPO** input (this input is not used in CSP mode).

Preparation for start-up:

- connect the battery terminals paying special attention to the correct polarity (reversed polarity can lead to permanent damage to the power supply);
- Switch on the W-BAT battery switch.

Start-up

1. Switching on the mains supply

- the green **ON** diode lights up permanently (power supply operation indication);
- a test of 5 LEDs is carried out, the LEDs light up one after the other and then go out, leaving the current operating status indication:



- short flashes of the **CIE** diode indicate correct operation of the **CIE** fire alarm wire parameterisation system;
- green colour of the **OUT** LED indicates presence of the mains power at the **OUT** output of the power supply.



LEDs that indicate inverter operation:

- ← lights up (indication of the presence of voltage at the inverter output)
- ← only temporary lighting during battery start-up of the inverter
- ← lights up (inverter operation from rectifier)

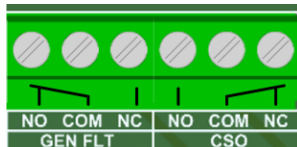

Relay outputs:

- GEN FLT** excited (no damage)
- CSO** not excited (no signal to open the gate)

2. Switching off mains power (switching to battery operation)

- the power supply switches to backup source (battery), which is indicated by the **OUT** diode turning yellow as soon as voltage from the inverter appears at the **OUT** output;
- after a short power failure, for the T_DLY time of 2s, the voltage from the inverter appears at the **OUT** output which is independently maintained in this state for the maximum TS time of 9min.



LEDs that indicate inverter operation:

- ← lights up (indication of the presence of voltage at the inverter output)
- ← lights up (battery powered inverter)
- ← turned off

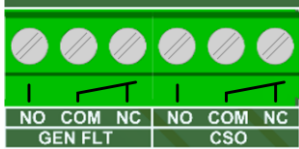

Relay outputs:

GEN FLT not excited (fault indication - no power supply)
CSO not excited (no signal to open the gate)

3. Transmission of a fire alarm signal to the CIE input.

- at TS time, when battery operation is in progress, connect a 1kΩ resistor to the **CIE** input for longer than T_CIE 2s;
- from this moment on, at the **OUT** output supplied by the inverter, the voltage is maintained independently for a maximum TA time of 9min.



LEDs that indicate inverter operation:

- ← lights up (indication of the presence of voltage at the inverter output)
- ← lights up (battery powered inverter)
- ← turned off

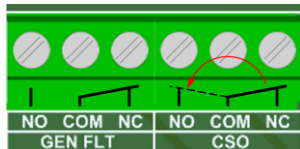

Relay outputs:

GEN FLT not excited (fault indication - no power supply)
CSO excited after T_CSO time of 12s, which triggers opening of the gate (if the gate controller is connected)

4. Return of mains power during gate opening

- at TA time, during operation triggered by a fire alarm, this alarm must be disabled (disconnect the 1kΩ resistor from the **CIE** input) and then restore the mains supply; *If a gate controller is connected to the power supply, it is advisable to perform this operation before the gate is fully open.*
- the power supply switches to main power source (mains), which is indicated by the **OUT** diode turning green as soon as voltage from the mains appears at the **OUT** output;
- the inverter enters standby mode which is indicated by its **ST-BY** LED;



- after a short voltage decay, for the T_DLY time of 2s, the mains voltage appears on the **OUT** output;
- the relay at the **CSO** output temporarily, at T_DLY + T_CSO time of 14s stops being excited and after TA time of 9min switches off permanently, *If a gate controller is connected to the power supply, the return of the CSO signal should resume the gate movement if it has stopped during a temporary mains power failure.*
- after the TA time of 9min has elapsed, the power supply returns to the state described in step 1 of start-up.
*The TA time countdown can be interrupted (shortened) by pressing the **RUN** button.*

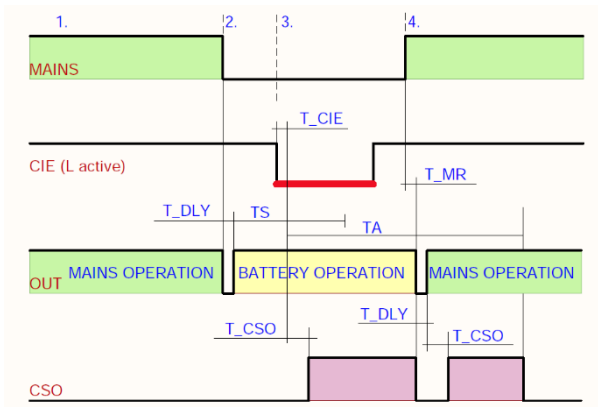

The time course shows the entire start-up process with an indication of its successive steps.

5.8. Power supply configuration





On the ZUP-BM board there is a slide switch allowing to set the function of the power supply. Some of the settings require restarting the power supply, restarting by temporarily disconnecting the 230V mains and the battery until the ON diode goes out. In the table below, these particular slide switch positions are enclosed in rectangular brackets [].

Description of the **SETTINGS** switch sliders.

Item	Slide control in the OFF position - off		Slide control in the ON position - on	
[1.]	UPS mode operation (see 2.2.)		CSP mode operation TA = 9min (see 2.1.)	
2.	T_DLY delay in mains-battery-mains switching <u>off</u> (min. value of ~25 ms remains)		T_DLY delay in mains-battery-mains switching <u>on</u> (2s)	
3.	CIE signal - active low state: shorted terminals or low resistance (1kΩ)		CIE signal - active high state: terminal open or high resistance (10kΩ)	
4.	For CSP mode CIE input parameterisation off. (shorted - open).	For USP mode DO signal - switch operation (see 3.2.)	For CSP mode CIE input parameterisation on (1kΩ/10kΩ).	For USP mode DO signal - static operation (see 3.2.)
[5.]	See the following table of Ah section settings.			
[6.]				
7.	T_CS0 delay Gate opening: 2s		T_CS0 delay Gate opening: 12s	
[8.]	CSO output for CSP mode - triggers the opening of the gate	CSO output for UPS - mode indicates low battery	The CSO output for both modes, CSP and UPS, - signals the loss of the 230V mains supply.	
9.	EPO signal - active low state (terminals shorted)		EPO signal - active high state (terminals open)	
Only for CSP mode				
10.	With the mains supply present, after the alarm on the CIE wire is terminated, the voltage on the OUT output disappears after a TA time		When the mains supply is present, despite the disappearance of an alarm on the CIE wire, the voltage at the OUT output remains even after TA time.	

11.	CSO output switched on continuously (only when gate opening activation is selected: slider 8 in OFF position).	CSO output switched cyclically: pulse 5s and pause 5s (only when gate opening activation is selected: slider 8 in OFF position).
[12.]	Switching to the mains supply during the TA time countdown (will temporarily interrupt the power supply at the OUT output).	Switching to mains supply will only take place after the set TA time has elapsed.

Slide switch settings in the **Ah** section. Slide positions **5 and 6**

Power supply type	Selected battery capacity and charging current			
				
ZUP-230V-BM-400	-	-	12Ah / 1A	18 and 22Ah / 2A
ZUP-230V-BM-700	12Ah / 1A	18 and 22Ah / 2A	26Ah / 2A	33Ah / 2A
ZUP-230V-BM-1000	18 and 22Ah / 2A	26Ah / 2A	33Ah / 2A	45Ah / 2A
ZUP-230V-BM-1500	26Ah / 2A	33Ah / 2A	45Ah / 2A	50...75Ah / 2A

Maximum additional resistance $R_{i\ max}$ in the battery circuit in mΩ.

Power supply type	Battery capacity						
	12Ah	18Ah	22Ah	26Ah	33Ah	45Ah	50...75Ah
ZUP-230V-BM-400	99	121	121				
ZUP-230V-BM-700	46	69	69	83	90		
ZUP-230V-BM-1000		33	33	47	54	50	
ZUP-230V-BM-1500				19	26	23	23

The following shows the status of the **SETTINGS** switches for the factory settings and a table describing the functions selected with them.



Slider No.	Slider position	Description
1.	ON	Operation in CSP mode
2.	ON	Output voltage dtop time T_DLY : 2s.
3.	OFF	Fire alarm triggered by a low state.
4.	ON	CIE input parameterisation enabled (1kΩ/10kΩ).
5.	x	Position of sliders according to power supply type
6.	x	
7.	ON	T_CSO delay for gate opening: 12s
8.	OFF	CSO output triggers gate opening
9.	ON	EPO input active with high state (terminal open)
10.	ON	The voltage at the OUT output is maintained even though the alarm has been cancelled
11.	OFF	The CSO output is switched on continuously.
12.	OFF	Switching to mains supply can take place during the TA time countdown.

The setting of sliders 1, 10 and 12 indicated above are required to ensure that the power supply complies with the EN54-4 standard.

6. Maintenance and service

- **Service personnel may only replace the indicated fuse with a fuse of the same parameters and type as that used in the device.**
- **All warranty and post-warranty repairs are carried out by the manufacturer's service department or by a specialised unit authorised by the manufacturer.**

Maintenance

The device does not require any special maintenance. During normal operation, the only action required is to keep the surroundings of the power supply reasonably clean.

Battery

- If the power supply system is expected to be left without mains power for a long time, disconnect the battery pack from the power supply. Leaving the battery attached may lead to its deep discharge and consequent damage.
- Battery life decreases noticeably with an increase in ambient temperature. An increase in temperature by every 8÷10°C shortens the life span by half.
- According to CNBOP-PIB and VdS recommendations, batteries should be replaced regardless of their condition after 4 years of operation.

Translated with www.DeepL.com/Translator (free version)

Service

The following is a list of fuses available to service personnel that can be replaced in the event of damage.

Description of an element in the power supply	Manufacturer	Type	Size	Value
Fuses in all ZUP-230V-BM power supplies				
CHARGER	SIBA	179020	5 x 20mm	10AF
OUTPUT	SIBA	179120	5 x 20mm	10AT
Fuse in battery circuit for ZUP-230V-BM-400, -700, -1000				
W-BAT		gG	D02 (15 x 36mm)	63A
Fuse in battery circuit for ZUP-230V-BM-1500				
W-BAT	DF ELECTRIC	gG	CH22 (22 x 58mm)	100A
Fuse in additional module ZUP-230V-BM-24V				
	SIBA	179020	5 x 20mm	3.15AF

7. Additional information

7.1. Manufacturer's remarks

The manufacturer reserves the right to introduce design and process modifications not affecting the parameters of the product.

7.2. Compulsory technical inspection

The ZUP-230V-BM power supply should be subjected to periodical technical inspection by the manufacturer's service or an entity authorised by the manufacturer

at least once a year during its entire life.

Any work carried out by unauthorised persons, or failure to carry out periodic inspection, may result in the loss of the manufacturer's warranty and will transfer the responsibility for the correct operation of the power supply to the user. The execution of the inspection should be confirmed by an appropriate protocol according to a model established by the manufacturer.

The user is obliged to ensure access to the devices to be inspected and to present documentation showing how the power supply is connected to the cooperating devices. It is recommended that such documentation, operational manuals for the power supply and associated equipment and inspection records are kept together and made available upon request by the manufacturer and during periodic inspection. It is also recommended that between inspections, during normal operation of the equipment, attention be paid to any electrical or mechanical damage, both to the power supply itself and to the associated equipment, which could affect the operation of the entire assembly. Any observations or concerns arising from this should be reported to the manufacturer for assessment of their potential impact on further operation.

Technical and service issues, as well as those related to periodic inspections, please contact directly the MERAWEX Service Department or a unit authorised by the manufacturer.

Note

The obligation to carry out regular technical inspections of fire protection equipment results from the ordinance of the Ministry of Internal Affairs and Administration of 7.06.2010 on the fire protection of buildings, other civil structures and areas (Dz. U. /Journal of Laws/ No. 109, item 719, Art. 3, sec. 3).

7.3. CE marking

 1438
MERAWEX Sp. z o.o. ul. Toruńska 8, 44-122 Gliwice, Poland 21 1438-CPR-0761
EN 54-4:1997 + AC:1999 + A1:2002 + A2:2006, EN 12101-10:2005 + AC:2007 Power supplies for fire gates and fire automation systems. ZUP-230V-BM-400S, ZUP-230V-BM-700S, ZUP-230V-BM-1000S, ZUP-230V-BM-700M, ZUP-230V-BM-1000M, ZUP-230V-BM-1500L DWU / DoP : DWU-MX-19 Other technical data: see operational manual

7.4. Handling of packaging, worn-out products and batteries



The product packaging is made of recyclable materials (wood, paper, cardboard, plastic). Unnecessary packaging should be sorted and handed over to a waste collector.



This marking on the product indicates that the product should not be disposed of with household waste at the end of its service life, but should be taken to a collection point for electronic waste. **Used batteries are hazardous waste and must be disposed of.** This will help to avoid damaging human health and the environment through uncontrolled waste disposal.